

# FlextraJoint T

## Installation guide

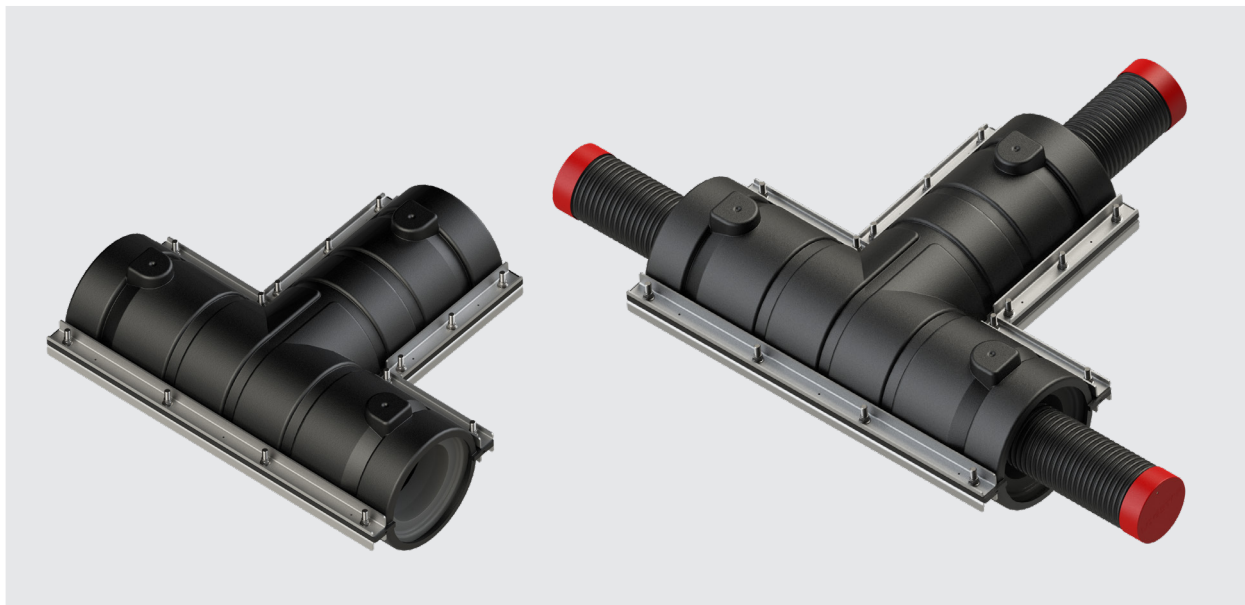

Installation video



### Part list

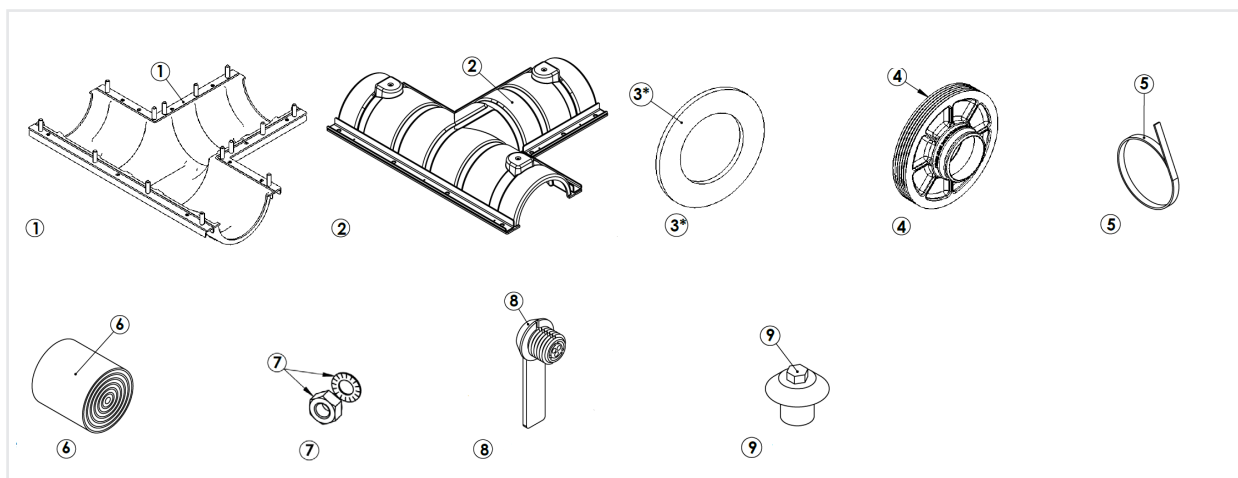

\* For casing diameter 90 - 140 mm  
Components (3) - (9) are packed in separate bags

# Installation procedure

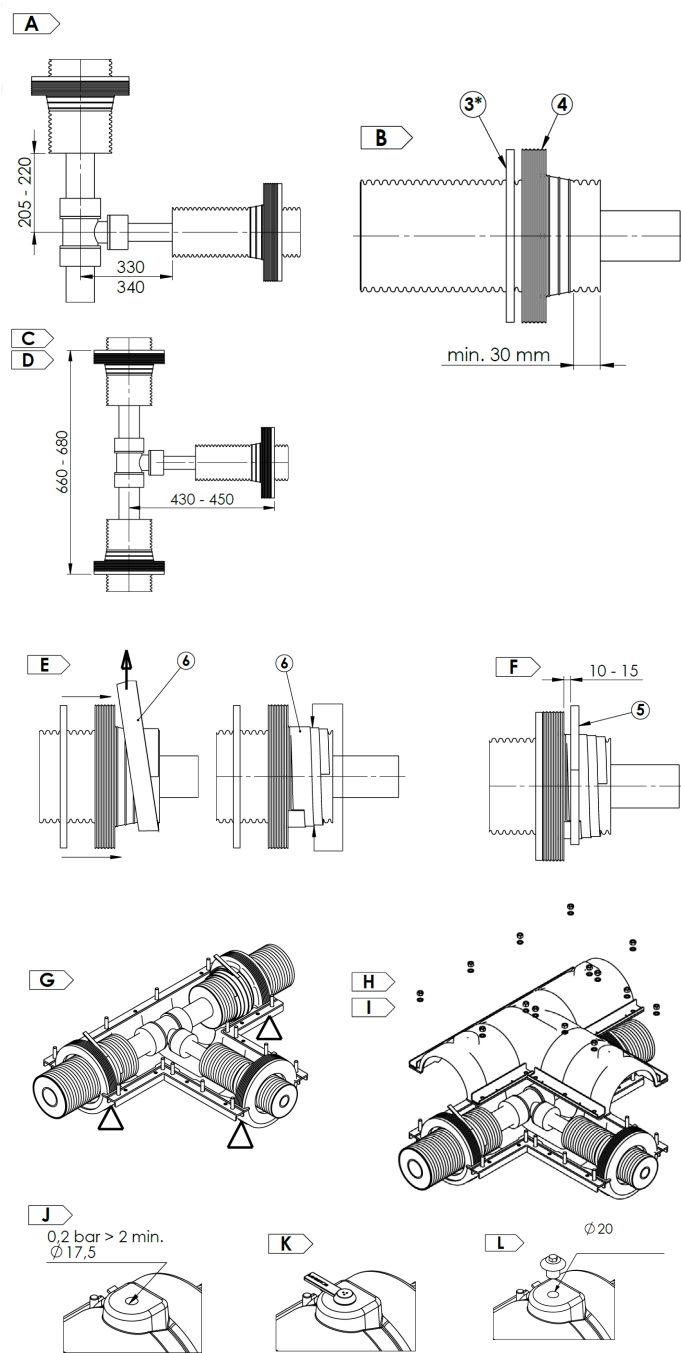

- A** Prepare free ends on pipes according chosen coupling and within shown measures.
- B** Clean the pipe with alcohol, put PE ring (3\*) and end seal (4) on casing.
- C** Install coupling
- D** Position the end seal (4) and PE ring (3\*) to fit PE part (1) and (2)
- E** Use mastic to seal between casing and end seal (4). Wind the mastic (6) from casing towards end seal, with 1/2 overlap.
- F** Secure end seal with cable tier (5).
- G** Remove backing tape from mastic and mount lower PE part (1) support the PE part. Make sure PE ring and rubber seal are inside.
- H** Clean contact surfaces on upper PE part and mount it. IMPORTANT: during positioning of the upper PE part - take care not to damage the thread on the bolts. When the upper PE part is mounted add a small amount of lubricant on each thread. Mount the washer before you apply lubricant. Lubricant type WÜRTH ceramic paste or Kema HTS-1400. Be careful not to contaminate the sealing areas with lubricant.
- I** Mount the nuts and washers (7) with hands before using tool. Tighten the nuts (7) - max 44 Nm. Tighten evenly starting from center towards ends. It is important to follow this order of tightening! Tighten the nuts to 44 Nm with torque wrench.
- J** Tightness test - 0,2 bar / 2 min. Check all sealings with soapy water.
- K** Install the venting plug (8) in one hole. Foam the joint through the other hole. Casings up to 140 mm with foam pack no.11, casings 160 and 180 mm - foam pack no.10. Install the other venting plug (8). If the casing dimensions are mixed, and you have a dimension from range 90 - 140 plus a dimension 160 or 180 the rule is you should use foam pack dedicated for larger dimensions: foam pack size 10 for FlextraJoint T.
- L** Remove venting plugs (8), remove excess foam, drill 20 mm holes - depth min. 30 mm, clean and grind plug area, install bolt plugs (9) by pressing it into the hole and tightening with a hand 7 mm socket tool. Tighten until visible mastic.

LOGSTOR Denmark Holding ApS  
Danmarksvej 11 | DK-9670 Løgstør

T: +45 99 66 10 00  
E: [logstor@kingspan.com](mailto:logstor@kingspan.com)



For the product offering in other markets please contact your local sales representative or visit [www.logstor.com](http://www.logstor.com)

Care has been taken to ensure that the contents of this publication are accurate, but Kingspan Limited and its subsidiary companies do not accept responsibility for errors or for information that is found to be misleading. Suggestions for, or description of, the end use or application of products or methods of working are for information only and Kingspan Limited and its subsidiaries accept no liability in respect thereof.

To ensure you are viewing the most recent and accurate product information, please scan the QR code directly above.

Second Issue | 09/2024

\* for pipe diameters 90 - 140

 **LOGSTOR**