

LOGSTOR TMC-C

Montageanleitung - Industrie



TMC-C

T-Muffe, offen

Montageanleitung

1/4

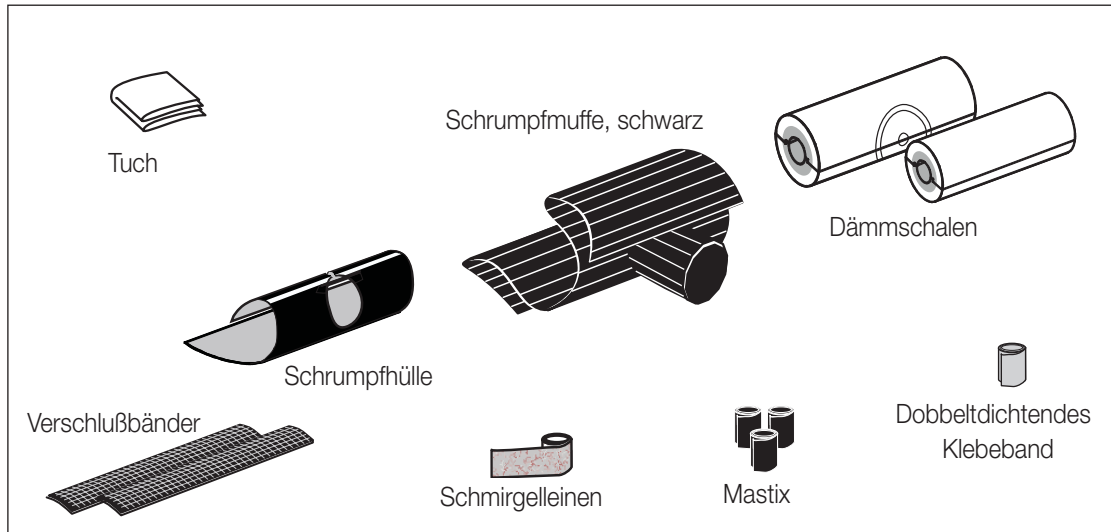

Wichtig:

Nie direkt auf etwaigen Falzen erwärmen, da sich das Werkstoff hierdurch verfärbt und an der Oberfläche rissig wird.

Nie unter der Muffen erwärmen, da dies zu nachhaltigen Schäden an der Muffe führen kann.

Etwaige Luftblasen unter der Muffe lassen sich mit Hilfe eines U-förmig gebogenen Schweißdrahtes beseitigen, der unter die noch warme Muffe geschoben wird.

Bei Muffen bis $\varnothing 200$ mm einen Brennerkopf $\varnothing 51$ mm, bei größeren Muffen einen Kopf $\varnothing 63$ mm benutzen.

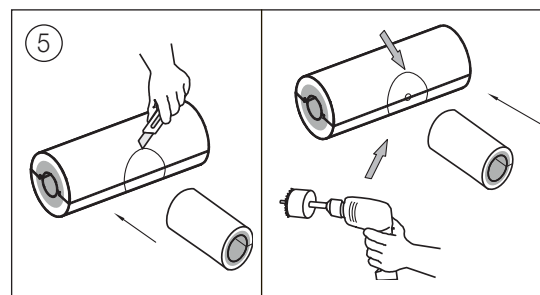
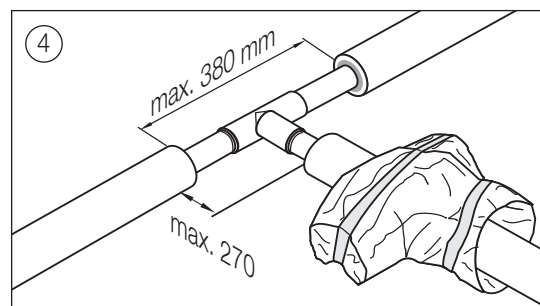
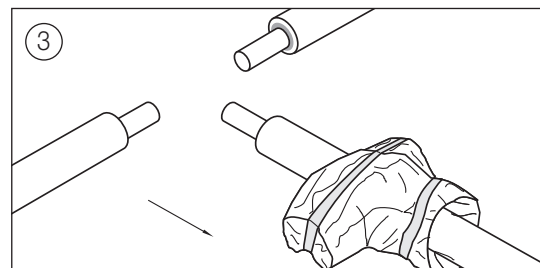
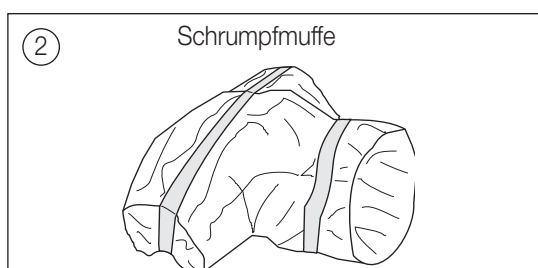
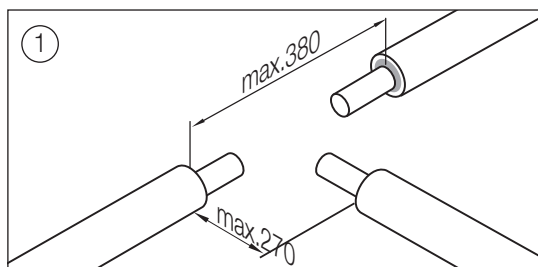

TMC-C

T-Muffe, offen

Montageanleitung

2/4

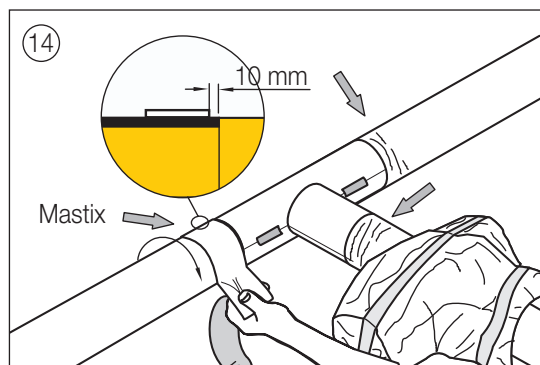
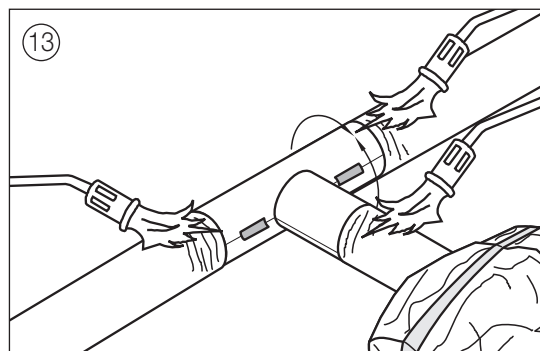
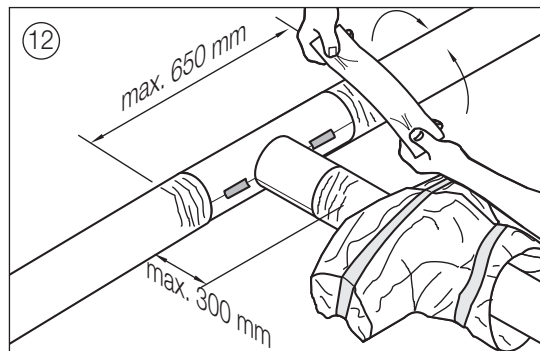
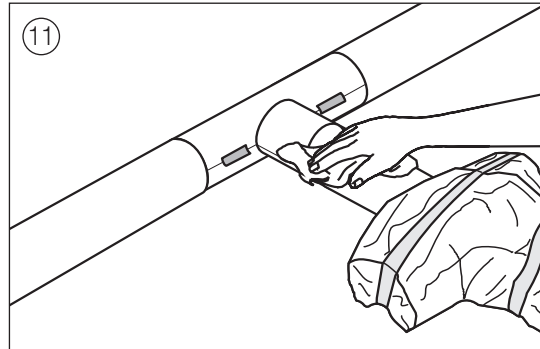
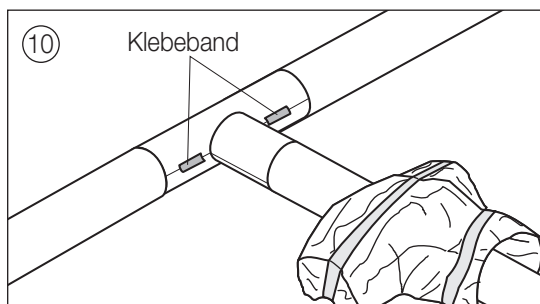
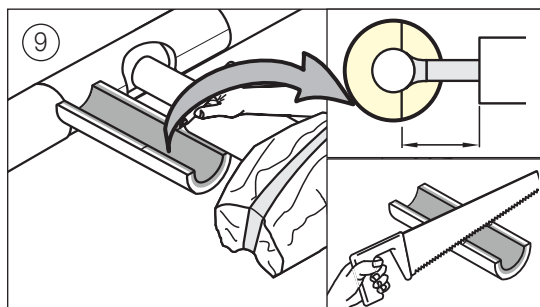
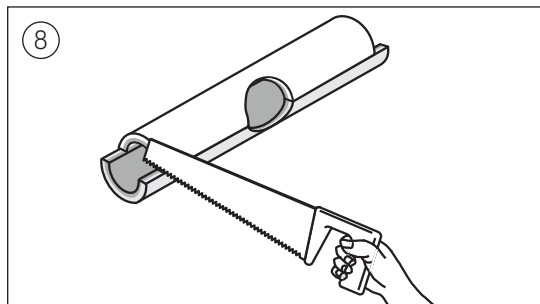
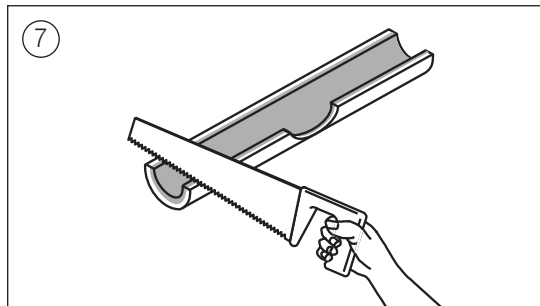
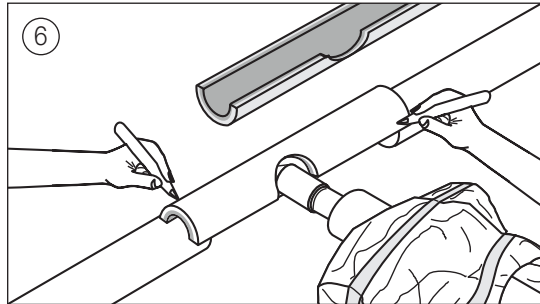

TMC-C

T-Muffe, offen

Montageanleitung

3/4

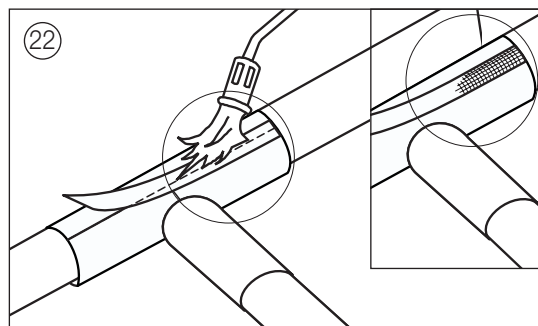
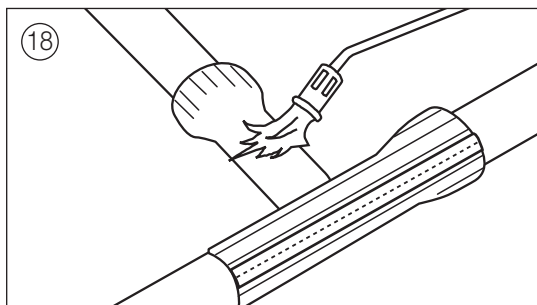
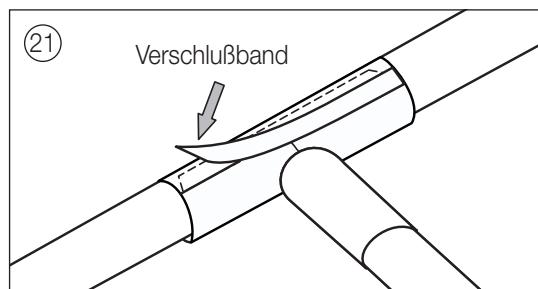
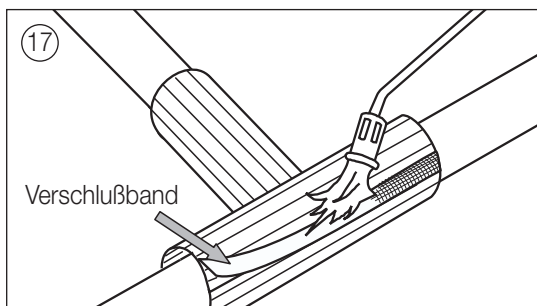
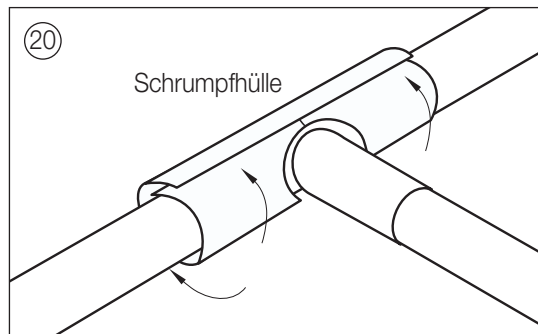
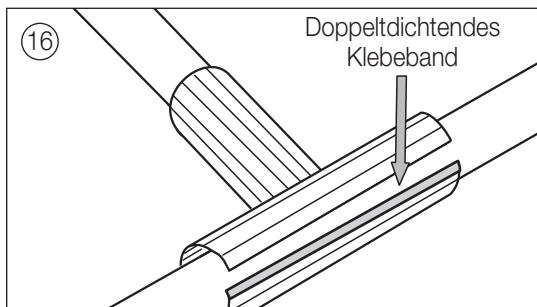
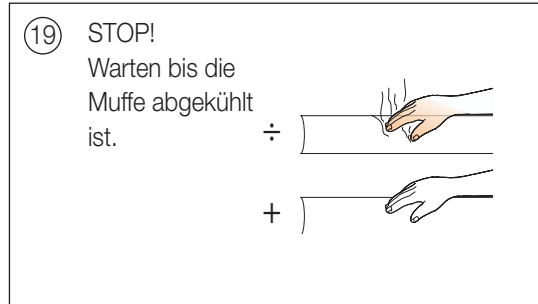
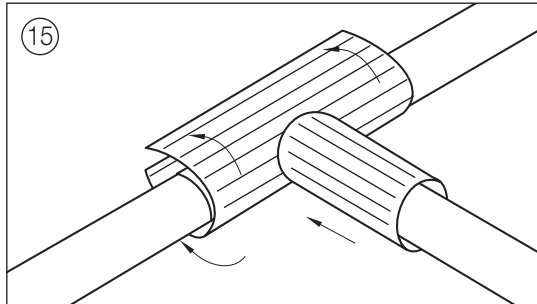

TMC-C

T-Muffe, offen

Montageanleitung

4/4

