

LOGSTOR TMC-C

Installation Instructions - Industry



TMC-C

T-joint, open

Installation instructions

1/4

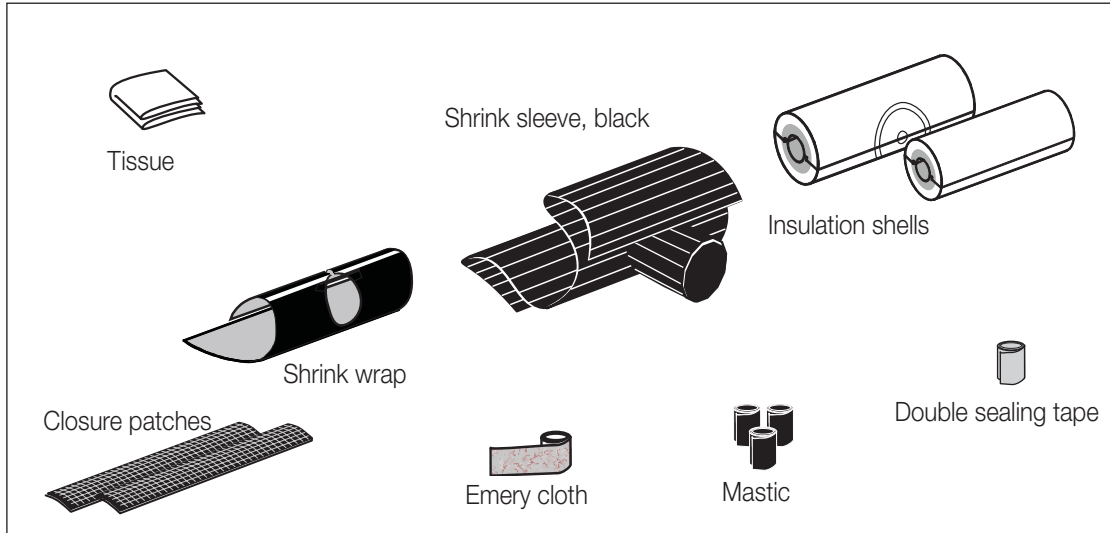

Important:

Never apply heat to creases, if any, since the sleeve material will be discoloured and the surface will crack.

Never apply heat underneath the sleeve at the ends, since this may damage the sleeve permanently.

Pockets of air under the sleeve can be removed by bending a piece of welding wire into U-shape and pushing it underneath the sleeve while it is still warm.

Use burner head $\varnothing 51$ mm for sleeves up to $\varnothing 200$ mm. For larger sleeves use burner head $\varnothing 63$ mm.

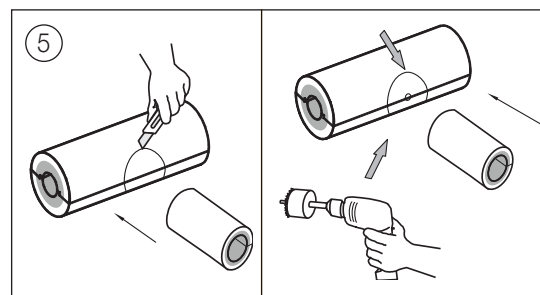
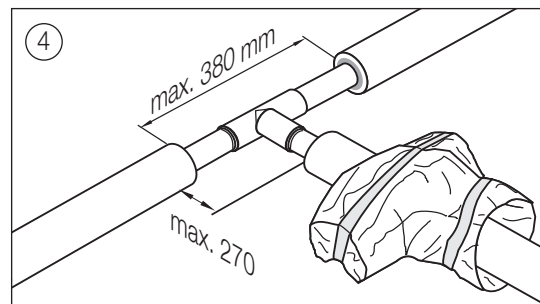
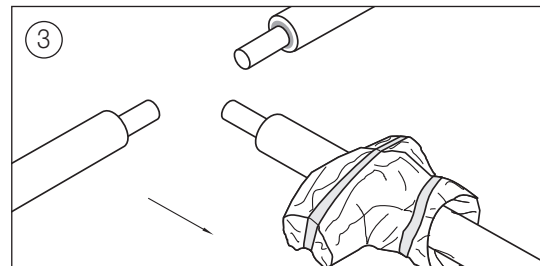
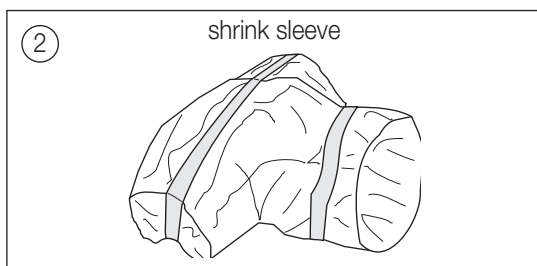
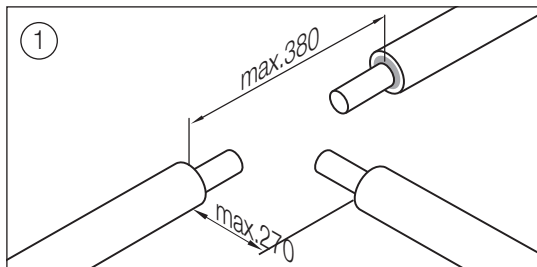

TMC-C

T-joint, open

Installation instructions

2/4

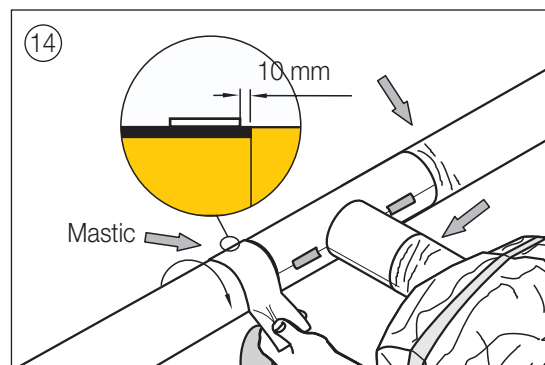
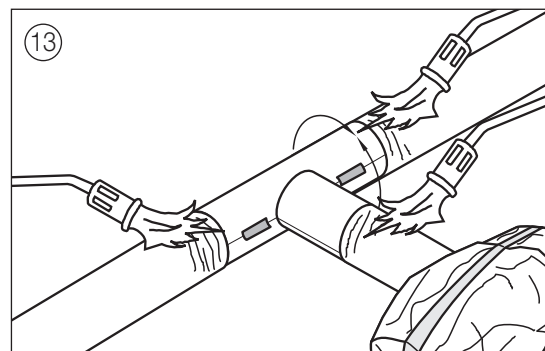
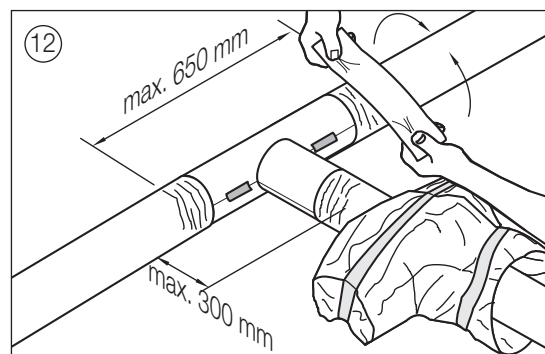
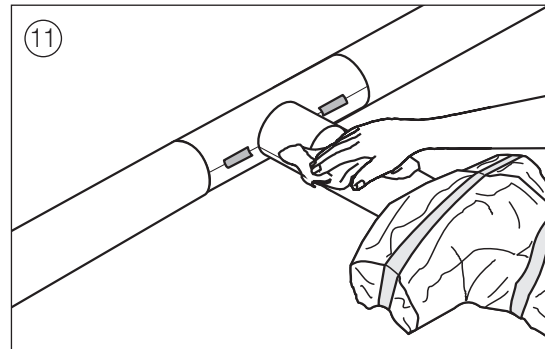
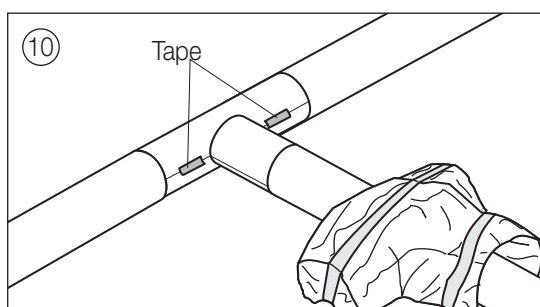
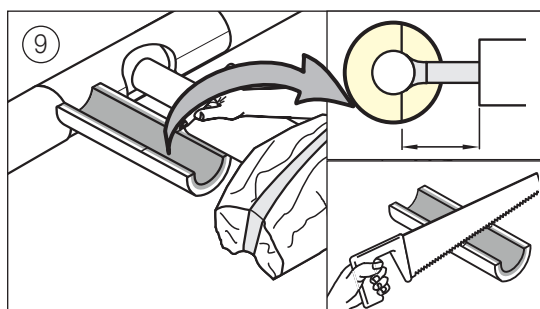
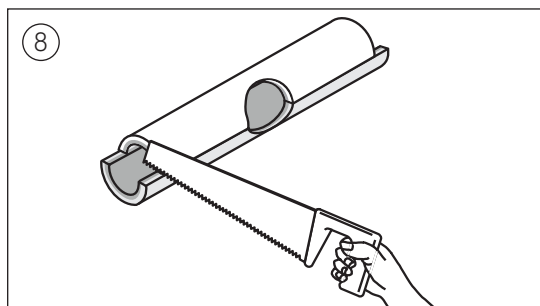
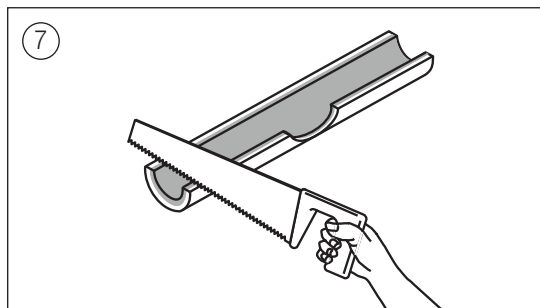
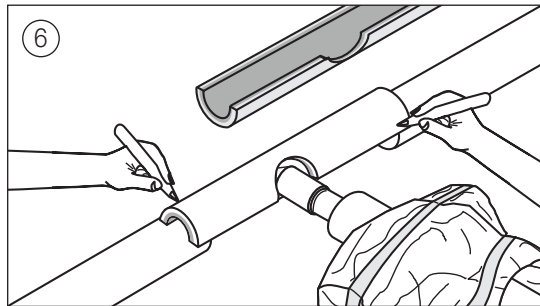

TMC-C

T-joint, open

Installation instructions

3/4

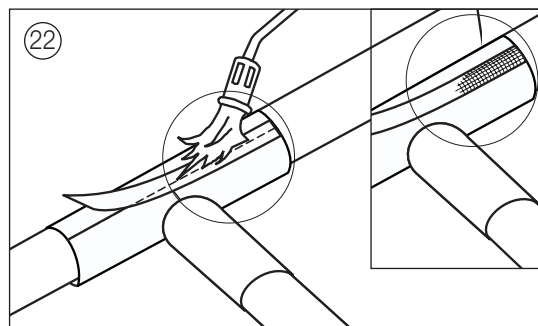
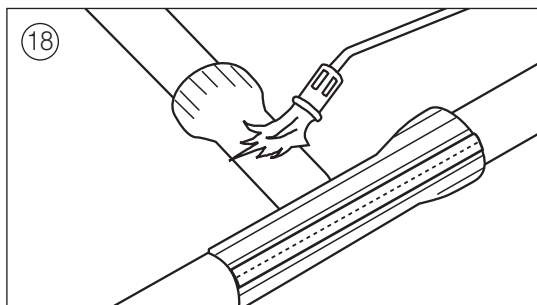
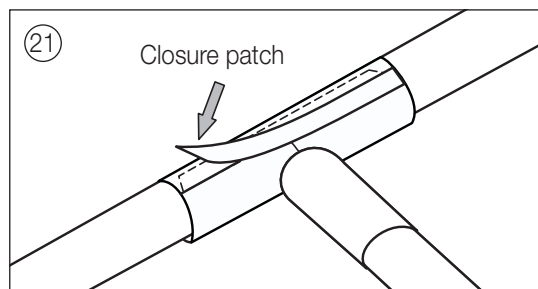
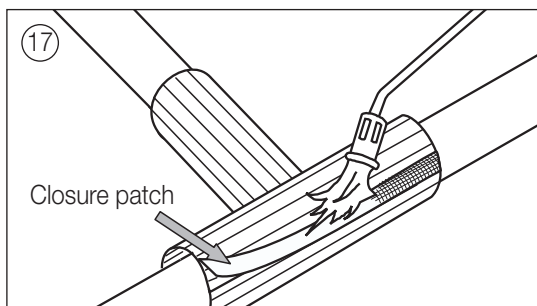
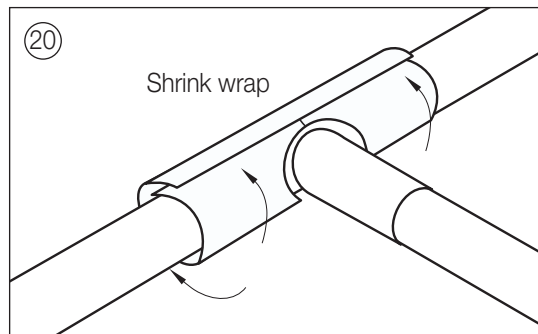
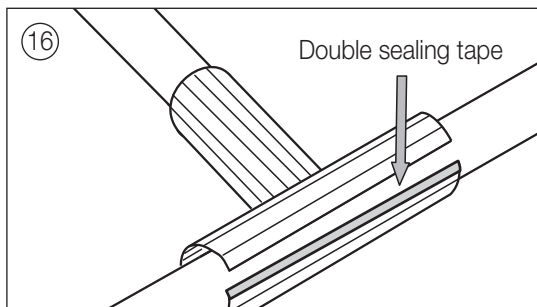
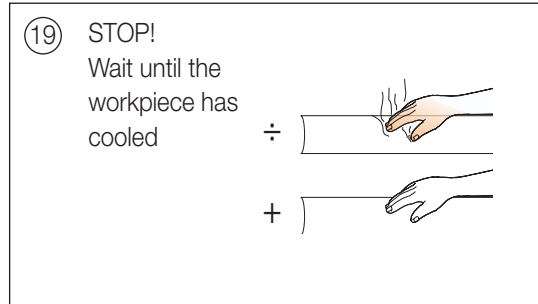
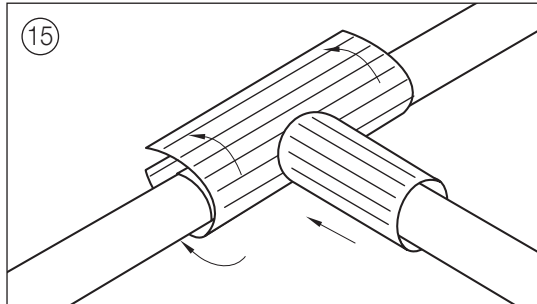

TMC-C

T-joint, open

Installation instructions

4/4

