

# LOGSTOR EC

## Installation Instructions - Industry



# EC

## End cap, white

# Fitting Instructions

# 1/2

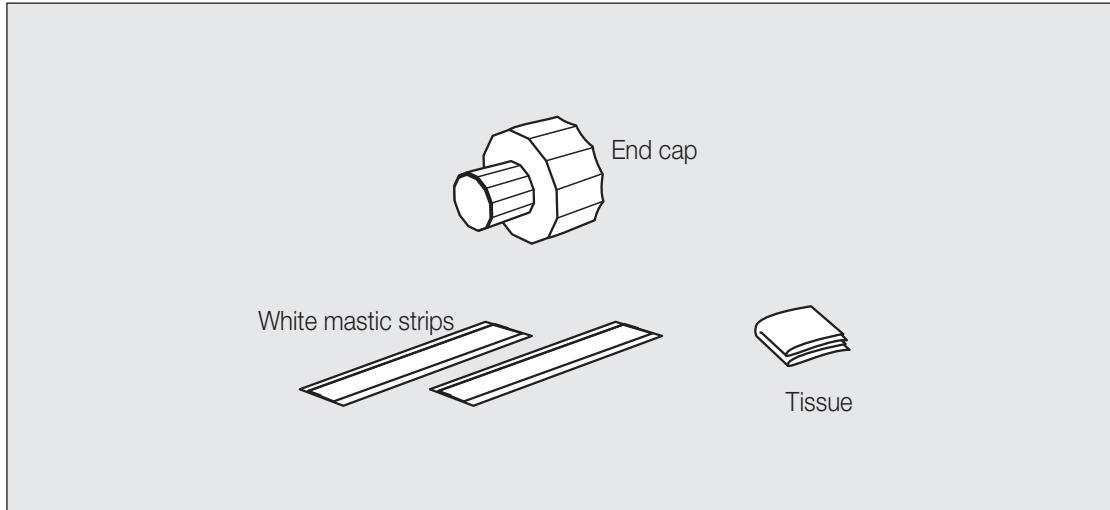

Necessary tools:

Gas burner, abrasive cloth, knife and saw.

**Important:**

Never apply heat to creases, if any, since the material will be discoloured and the surface will crack.

Never apply heat underneath the end cap, as this may damage the end cap permanently.

Pockets of air under the end cap can be removed by bending a piece of welding wire into U-shape and pushing it underneath the sleeve while it is still warm.

Use burner head dia. 51 mm for end caps up to dia. 200 mm. For larger end caps use burner head dia. 63 mm.

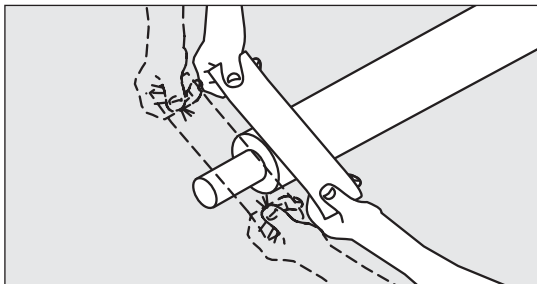

1. Check that the pipe end is CLEAN and DRY.  
Activate the jacket and steel pipe with abrasive cloth at least 60 mm from the end of the jacket pipe.

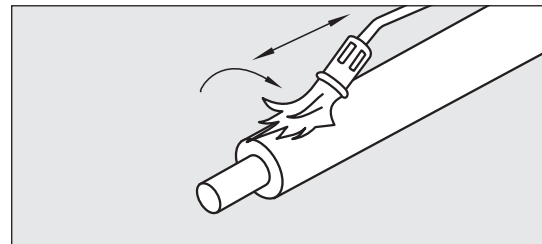

2. Activate the jacket with the flame at least 60 mm from the end of the jacket pipe until the surface has a matt, silky look.

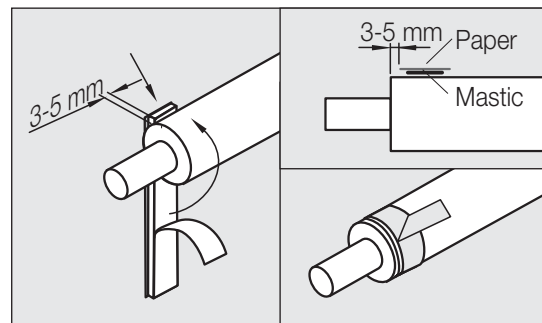

3. Remove the protective film from the mastic strip and place the adhesive side face down on the jacket approx. 3-5 mm from the end of the jacket pipe. Make a loop with the protective paper.

# EC

## End cap, white

# Fitting Instructions

# 2/2

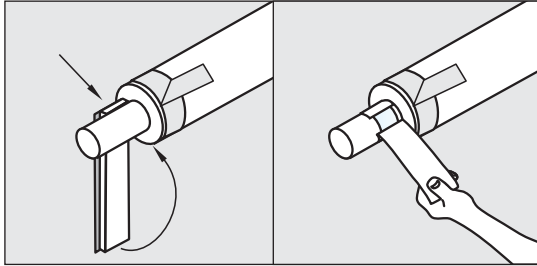

4. Remove the protective paper from the mastic strip and place the adhesive side face down on the steel pipe as close to the insulation as possible. Remove the protective paper.

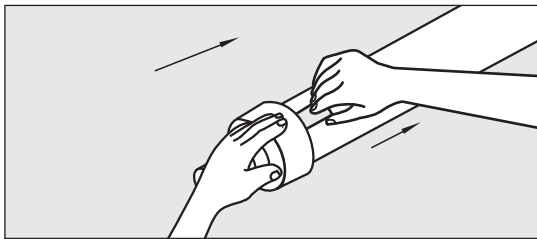

5. Remove the packing from the end cap. Check that it is CLEAN and DRY, inside and out. Pull the end cap onto the steel pipe and mastic strips. Remove the protective paper from the mastic strip.

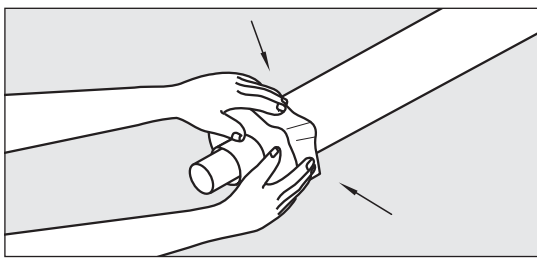

6. The end cap is fastened by pressing the upper part against the mastic strip at 2-3 places.

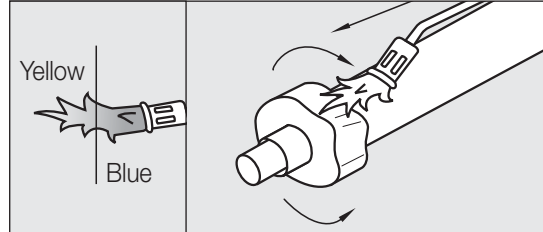

7. Adjust the flame so that the yellow measures approx. 8-10 cm. Start shrinking the end cap onto the jacket. Make sure that heat is not applied directly onto the edge, as the jacket material will be discoloured.

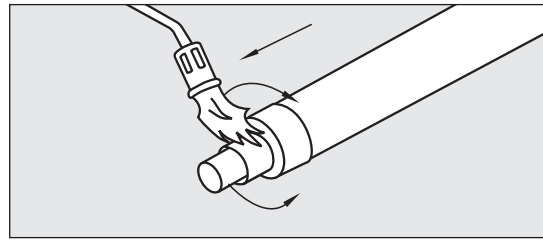

8. After a pause of approx. 1 min. shrink the end cap onto the carrier pipe.

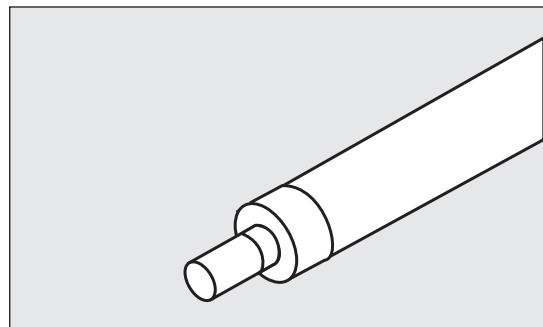

9. The end cap is complete.

