

Pipe-in-Pipe sliding system

The LOGSTOR Pipe-in-Pipe offshore hot applications solution consist of steel inner pipe, steel outer pipe (with corrosion protection), and PUR foam bonded onto the inner pipe. The outer pipe is able to slide on the insulation.

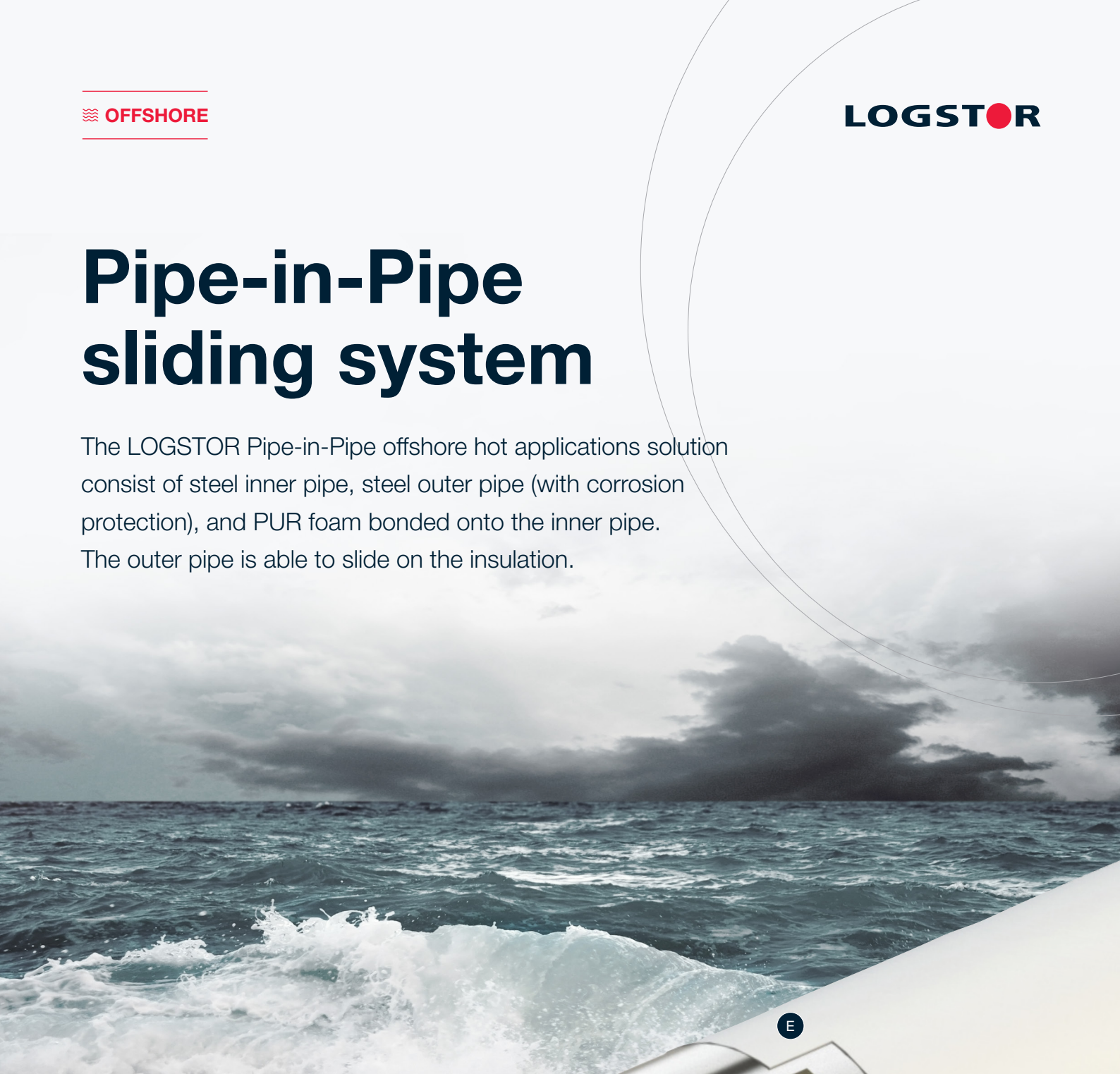

PRODUCT DESCRIPTION

- Steel inner pipe
- Steel outer pipe with AC Coating (FBE, 3LPE, 3LPP)
- Foam Density $95 \pm 15 \text{ kg/m}^3$
- Lambda value of 0.03 W/mK
- Operation temperature max. $140 \text{ }^\circ\text{C}$
- Achievable U-value at $0.4 - 1.5 \text{ W/m}^2\text{K}$ referenced to inner steel pipe OD

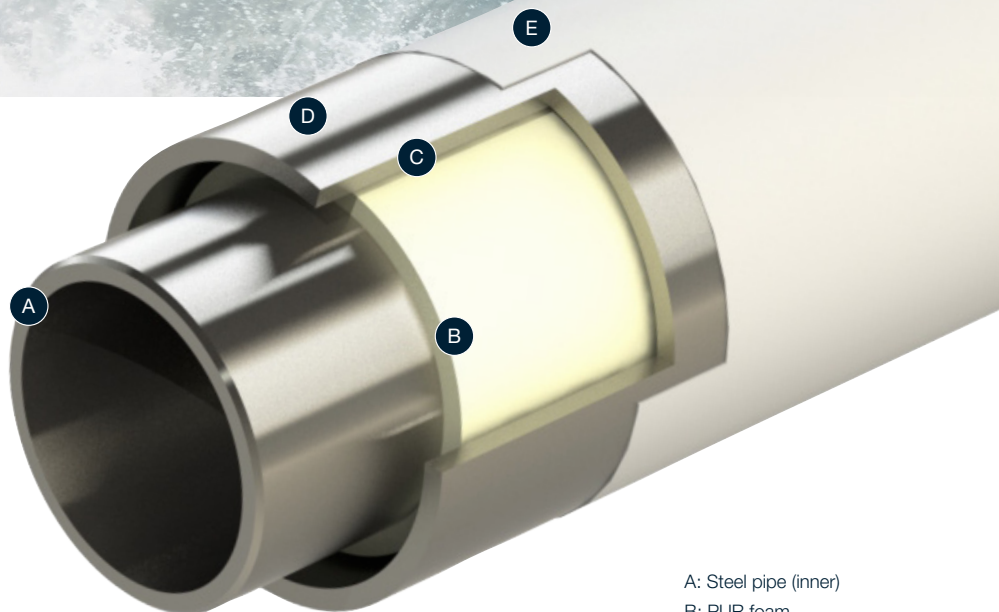

- A: Steel pipe (inner)
- B: PUR foam
- C: Air gap
- D: Steel pipe (outer)
- E: AC coating

Pipe-in-Pipe sliding system

SYSTEM MAIN FEATURES

- The pipes can be installed using S-lay, tow-out or J-lay methods. Standard length of each pipe is 12.2 m, can also be supplied as double-joint, or as specified by client.
- The sliding ability of the outer pipe ensures an optimal process during installation, where the pipes can be assembled with just one weld on the inner pipe, and one weld on the outer pipe.
- Design life is 30 years.

PLANT CAPABILITIES

- Pipe lengths typical 12 m, possibility up to 24 m
- Pipe weight up to 20 tons
- The range of inner steel pipe sizes is 6 – 24"
- The outer steel pipe is 10 – 32", depending on U-value requirements

LOGSTOR

ABOUT LOGSTOR

LOGSTOR is a global energy company with a focus on providing better energy efficiency to our customers. Our company is based on years and years of experience and know-how related to insulation as a means of improving energy efficiency and pipeline flow assurance.

(V.1.0)

COMPANY FACTS

- Head Office in Denmark
- More than 50 years of experience with an extensive track record
- Around 200 000 km of delivered insulated pipes
- Complete end-to-end solutions

HEAD OFFICE

LOGSTOR A/S
Danmarksvej 11
DK-9670 Løgstor
Tel: +45 9966 1000
logstor@logstor.com
www.logstor.com

APPLICATION PROCESS



Steel pipe pre-heated

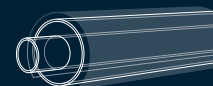

Insertion of steel pipe in the mold



Closing of the heated mold



Injection of insulation

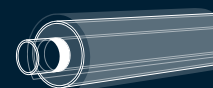

Opening of the mold and pipe release



Insert into the outer pipe



Pipe inspection ready for dispatch